

**Grade Nine Mathematics
Final Exam Review 2018**

Unit 1 Square Roots and Surface Area

1. Find the indicated square roots: $\sqrt{\frac{25}{36}}$ $\sqrt{\frac{2}{18}}$ $\sqrt{\frac{121}{81}}$

2. What is the square root of: A) 9 B) $\frac{36}{81}$ C) $\frac{144}{64}$

3. What is the square of: A) 16 B) $\frac{4}{9}$?

4. Find the number that has a square root of $\frac{3}{5}$.

5. Estimate: A) $\sqrt{\frac{102}{37}}$ B) $\sqrt{\frac{125}{17}}$

6. Find a number that has a square root between 4.1 and 4.2.

7. Determine a reasonable estimate for $\sqrt{0.08}$

8. A student wrote on a quiz that $\sqrt{57}$ was between 49 and 64. Should this student receive full marks?

9. You are covering the top of a square stool with felt. The area of the top is 270 cm². Estimate the length of one side of the top of the stool. Would 60 cm of trim be enough to completely go around the top of the stool?

10. Graph $\sqrt{27}$ on a number line.

11. Jordan wants to make a square flower bed and plant 24 perennials that are evenly spaced. The landscaper recommends that he allow 1.5 m² per plant. How long should Jordan make each side of his square flower bed?

12. A square garden has an area of 50 m^2 . What is a good estimate the dimensions of the garden?
13. Samantha is answering a question on her Math Assignment and she states that the square root of 900 is 450. Is she correct? Explain your answer.
14. Determine the surface area of each composite shape.

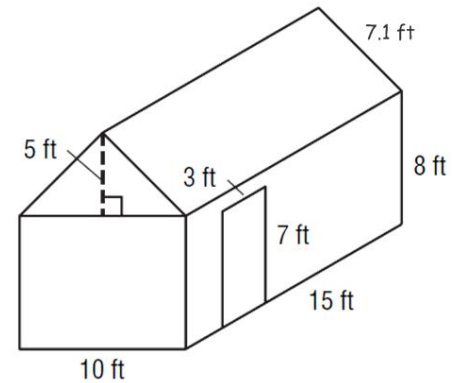
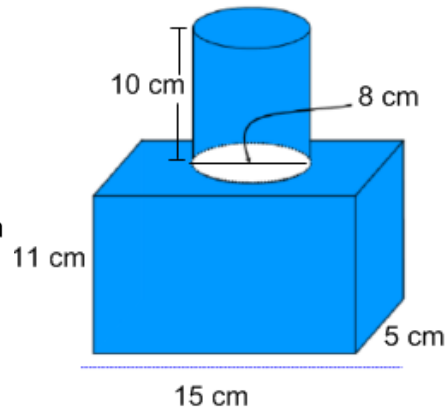
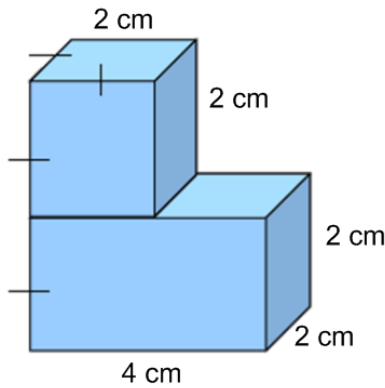

*** Note that for the house, the floor and door are not included.**

Chapter Two: Powers and Exponent Laws

- Explain why 3^5 is not the same as 5^3 .
- Evaluate each power. a) 5^0 b) -2^0 c) $(-7)^0$
- Evaluate. a) $6^0 - 3^0$ b) $(2 + 2)^3$ c) $6^2 + 6^2$ d) $4^3 \times 2^3$
- Evaluate. a) $(9 \div 3^2 + 1)^4 - 4^0$ b) $3^3 \div 9(3^0 - 2^2)$ c) $(12^2 + 5^3)^0 - 2[(-2)^3]$

5. Complete this table.

Power	Base	Exponent	Repeated Multiplication	Standard Form
5^3				
$-(-2)^5$				
	-4	2		
			$1 \times 1 \times 1$	
			$(-2)(-2)(-2)(-2)$	
			$3 \times 3 \times 3 \times 3 \times 3 \times 3$	
			$-(8 \times 8 \times 8)$	
	-5	2		
-3^4				
$(-1)^7$				

6. Write each product as a single power.

- a) $4^3 \times 4^2$ b) $(-2)^2 \times (-2)^4$ c) $8^7 \div 8^5$ d) $\frac{(-9)^{10}}{(-9)^4}$
- e) $2^3 \times 2^6 \div 2^9$ f) $(-5)^8 \div (-5)^4 \times (-5)^3$ g) $\frac{6^3 \times 6^5}{6^2 \times 6^4}$ h) $2^4 \times (2^5)^5$
- i) $(3^4)^2$ j) $-(7^2)^2$ k) $[(-3)^3]^2$

7. Write each as a product/quotient of powers. a) $[(-4) \times 3]^2$ b) $(10 \div 5)^3$ c) $\left(\frac{1}{10}\right)^6$

8. Sally recently wrote a test and answered the question shown below. However she made a mistake in her solution. Find the mistake, circle it, and write the correct solution.

Sally's Solution	Your Solution
$(7 - 5)^3 \times (8 + 2)^4$ $(2)^3 \times (10)^4$ 6×10000 60000	

9. Simplify, then evaluate.

a) $2^2 - 2^0 \times 2 + 2^3$

b) $(-2)^6 \div (-2)^5 - (-2)^5 \div (-2)^3$

c) $\frac{3^4}{3^3} + \frac{4^2 \times 4^0}{2^4}$

10. Simplify, then evaluate each expression

a) $(2^3 \times 2^1)^2$

b) $(5^4 \div 5^2)^2$

c) $[(-3)^0 \times (-3)^3]^2$

d) $(10^2)^4 \div (10^3)^2$

e) $(3^2 \times 4^3)^2 - (4^4 \div 4^2)^2$

f) $(2^3 \div 2^2)^3 + (7^4 \times 7^3)^0$

g) $[(-1)^3]^4 - [(-1)^4 \div (-1)^3]^2$

11. Find the error in the solution, circle it, and then write out the proper solution.

Wrong Solution	Correct Solution
$(2^2 + 2^3)^2 = (2^5)^2$ $= 2^{10}$ $= 1024$	

Chapter Three :Rational Numbers

1. Write the rational number represented by each letter as a decimal.

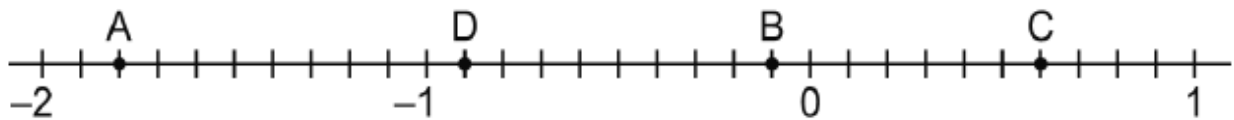

2. Write the rational number represented by each letter as a fraction.

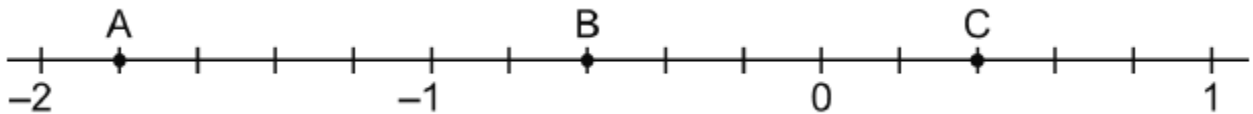

3. Order the numbers from greatest to least $-2.25, \frac{5}{4}, -1.5, -\frac{1}{8}, 0.9$

4. Identify a rational number that is between the two given . A) -0.7 ___ -0.71 B) $\frac{-2}{3}$ ___ $\frac{-3}{4}$

5. Solve

A) $(-6.5) + (-4.2)$ B) $(-0.75) - (-0.4)$ C) $\left(-\frac{7}{8}\right) + \left(\frac{5}{6}\right)$

D) $\left(-1\frac{2}{3}\right) - \left(\frac{1}{2}\right)$ E) $2\frac{3}{8} + \left(-1\frac{5}{6}\right)$ F) $\frac{4}{5} - \left(-2\frac{1}{4}\right)$

G) $(-1.25) \div (0.5)$ H) $(7.2) \times (-3.5)$ I) $\left(\frac{-18}{5}\right) \times \left(-\frac{1}{2}\right)$

J) $\left(-\frac{2}{5}\right) \div \left(\frac{3}{10}\right)$ K) $\left(-2\frac{1}{4}\right) \times 1\frac{2}{3}$ L) $\left(-1\frac{1}{4}\right) \div 3$ M) $\left(\frac{3}{4}\right)^2 \div \frac{1}{4} + \frac{1}{3}$

N) $\left(-\frac{3}{7}\right)^2$ O) $-2\frac{1}{3} + \left(\frac{2}{3} - \frac{5}{6}\right) \div \frac{5}{12}$ P) $\left[\left(1\frac{5}{6} - 2\frac{1}{2}\right) \div \left(\frac{-1}{2}\right)^2\right] \times \frac{3}{4}$

6. Find the mistake, circle it, and write out the proper solution.

Wrong Solution	Correct Solution
$-8.6 \times 14.6 - 5.3 \div (-16.4 - 8.6)$ $= -8.6 \times 14.6 - 5.3 \div (-25)$ $= -124.7 - 5.3 \div (-25)$ $= -130 \div (-25)$ $= 5.7$	

7. A submarine recorded temperature readings during the $3\frac{1}{4}$ hours of its descent to the bottom of the ocean. The total change in temperature was $-18\frac{3}{4}^{\circ}\text{C}$. Find the mean hourly change in temperature. Find the change that would be expected for each quarter hour. Write out the equation and solution

8. On their vacation, the Simms spent $\frac{1}{4}$ of their money on gas, $\frac{1}{4}$ on food and lodging and $\frac{1}{8}$ on tourist attractions. What fraction of their money did they spend? If they started with \$840.00, how much money did they have left? Write out the equation and solution.

Chapter Four :Linear Relations

1. Jamie plants trees. She was paid \$40 a day plus \$0.50 for every tree she planted.

A) Write an equation that relates Jamie’s earnings (E) to the number of trees (n) she plants.

B) One day Jamie planted 140 trees. How much did she earn that day

C) How many trees would Jamie need to plant in order to earn exactly \$100 in one day?

2. Identify these ordered pairs indicated in the diagram. [2 marks]

Point	J	E	D	I
Ordered Pair				

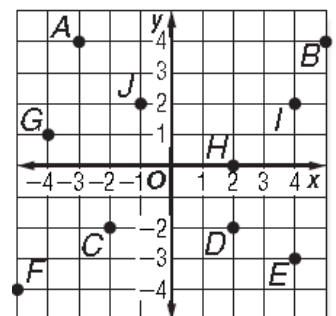

3. Consider this pattern of shapes.

A) Complete this table of values.

Figure# F	# of Hexagons H

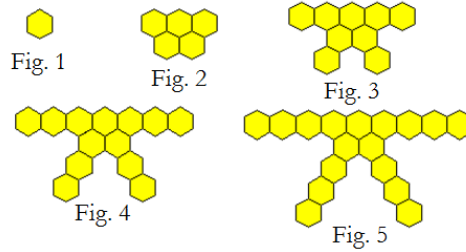

B) Write an equation that represents this linear relation.

4. The table shows the number of line segments in a set of diagrams. What is the equation?

Diagram Number, N	1	2	3
Number of Line Segments, d	4	7	10

5. Determine which of these four relations are linear and which are non-linear. Circle your answer.

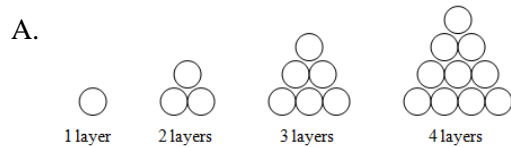

B. $2x - 3y = 10$

C.

X	1	2	3	4	5	6
Y	256	225	196	169	144	121

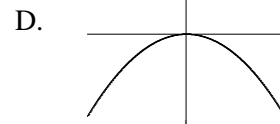

6. Use the graph to complete a table of values and find the equation of the linear relation.

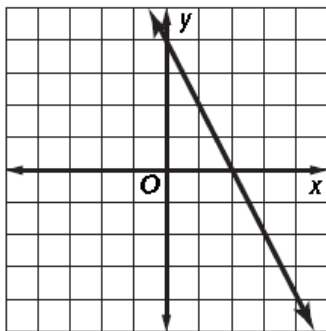

7. Complete a table of values and graph the data for the equation $2x - y = 2$

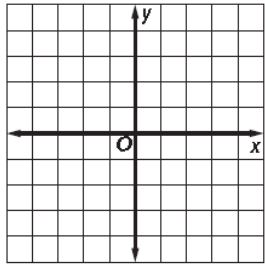

8. Graph each equation:

A) $2x + 5 = 11$

B) $x = -2$

C) $y = 1$

D) $6 - y = -3$

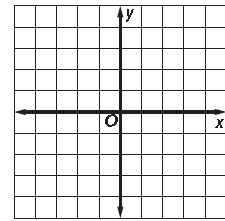
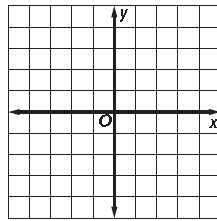
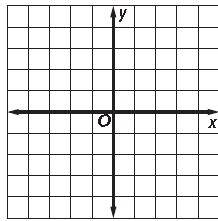
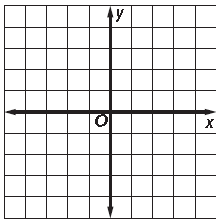

9. Identify if these equations describe a vertical line, a horizontal line, or an oblique line.

A) $y + 7 = -5$

B) $8x = 5 + y$

C) $14 = 9 + x$

10. A Maid-4-Hire company charges \$10 per hour plus a flat rate for their services as the table shows.

A) Is this a linear relation?

B) What are the dependent and independent variables?

C) Create the equation.

D) How much would it cost to hire a maid for 2.5 hours?

E) How long could a maid be hired for \$85?

F) How much would it cost to hire a maid for 10 hours?

Hours (h)	Cost (c)
0	50
1	60
2	70
3	80

11. Match each equation with a graph on this grid. Show all workings.

Equation #1: $y = 2x - 1$

Equation #2: $y = -x + 4$

Equation #3: $y = 3x - 3$

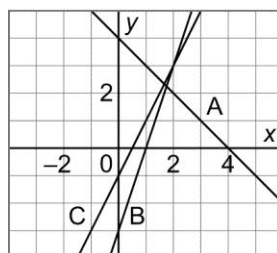

12. Match equations 1, 2, and 3 with their graphs A, B, and C. Show all workings

Equation #1: $y = 3x$

Equation #2: $y = x + 2$

Equation #3: $y = -2x + 1$

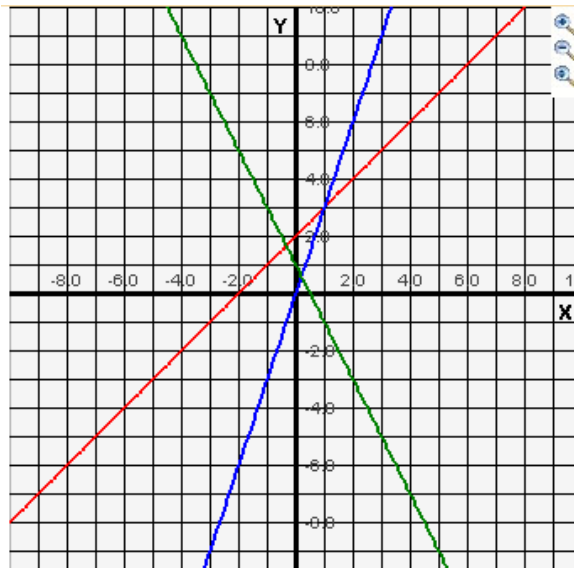

Chapter 5: Polynomials

1. Circle the expressions below which are polynomials; $2m^2 + 1$, $\sqrt{3x}$, $-4x$, $\frac{1}{x^2 + x}$, $0.25y^2$

2. Name the coefficients, variable, degree, and constant term of each polynomial.

Polynomial	Coefficient(s)	Variable	Degree	Constant Term	Name
$-8y$					
12					
$-2b^2 - b + 10$					
$-4 - b$					

3. Write a polynomial with 2 terms, degree 1, with a constant term of 4

4. Write a polynomial with 3 terms, degree 2, with the coefficient on the 2nd degree term -2 .

5. Circle which terms are like $2w^2$: $-5w$, $-6w^2$, -2 , $4w$, $3w^2$, $-w^2$, $11w$, and 2 .

6. **USE ALGEBRA TILES** to model:

$(2s^2 + 3s - 6) - (s^2 + s - 2)$

7. Add or subtract as required.

a) $y^2 + 6y - 5 + 2y - 7y^2$

b) $(-2n + 2n^2 + 2) + (-1 - 7n^2 + n)$

c) $(-2x^2 + 3x + 6) - (-x^2 + x + 2)$

d) $(2w^2 - 3w + 6) - (w^2 + 2)$

8. Using the diagram to the right:

a) Write a simplified polynomial to represent the perimeter of the rectangle.

b) Write a simplified polynomial to represent the area of the rectangle.

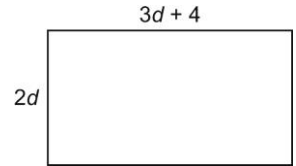

9. Use the diagram on the right and write a multiplication and a division statement:

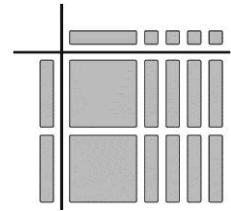

10. Multiply or divide by any method you chose

a) $(12c^2 - 6c) \div 3c$ b) $5p(-5 - 2p)$ c) $\frac{9xy - 6x}{-3x}$ d) $(7k - 3)(-m)$ e) $(-12x^2 - 9x - 12xy) \div (-3x)$

f) $(-5k^2 + k - 3)(-2)$

g) $(18x^2 - 6x + 6) \div (6)$

h) $-3(-5m^2 + 6m + 7)$

11. Circle the error in the solution below and write out the correct solution. (3 marks)

Wrong Solution	Correct Solution
$\begin{aligned} & \frac{21x^2 + 15x - 3}{-3} \\ &= \frac{21x^2}{-3} + \frac{15x}{-3} + \frac{-3}{-3} \\ &= -7x^2 - 5x + 0 \\ &= -7x^2 - 5x \end{aligned}$	

12. Find the expression for the area of the shaded region.

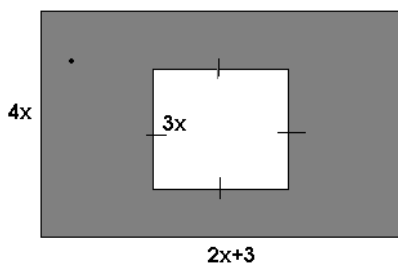

Unit 6: Equations and Inequalities

1. Solve each of the following equations.

A) $-\frac{3}{8}x = -12$

B) $3k + 5 = 29$

C) $\frac{2}{3}y - 8 = -2$

D) $\frac{-6}{9x} = 8$

E) $2(-2 + w) = 18$

F) $2.3x - 4.1 = -3.7x + 1.9$

G) $2(x + 2) = -(x - 19)$

H) $-2.1x = 4.3x + 80$

I) $2x + \frac{5}{3} = \frac{-1}{5}$

J) $\frac{3}{4}(4x + 2) = -\frac{5}{6}(x - 4)$

2. Solve the inequality:

A) $-2m + 5 < -3$

B) $3x \leq -12$

C) $2P + 3.25 < 0.75P - 5$

D) $2(2x - 3) < 7x$

3. Which inequality is represented below?

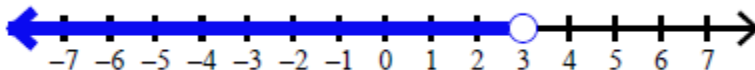

4. iTunes charges \$1.50 per download and a signup fee of \$15.00. Tunester just charges \$2.25 per download but has no download fee.

A. Write an equation to show when the two companies would charge the same amount.

B. Use the equation to show how many songs would you need to download for the cost to be equal.

C. Verify the solution

5. The perimeter of a square must be less than 40cm. Write an inequality to show the possible perimeter.

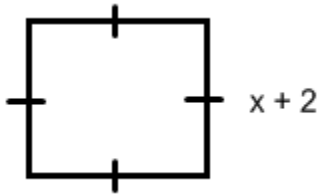

6. Find the student's mistake and circle it. Complete the proper solution

$$\begin{aligned}
 4(2x - 3) &= 61 \\
 8x - 3 &= 61 \\
 8x - 3 + 3 &= 61 + 3 \\
 8x &= 64 \\
 \frac{8}{8}x &= \frac{64}{8} \\
 x &= 8
 \end{aligned}$$

Chapter 7: Similarity and Transformations

1. Determine the scale factor for this scale drawing.

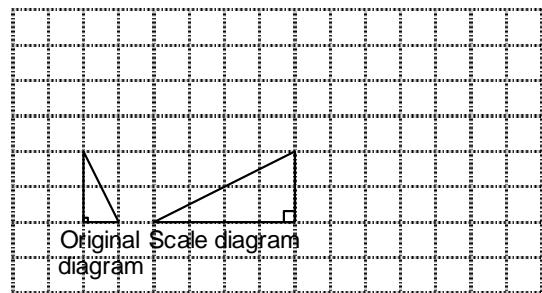

2. Which two triangles are proportional? Identify the scale factor for the reduction.

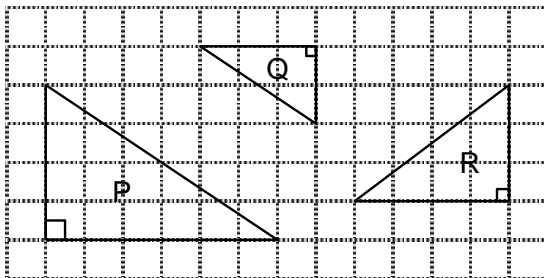

3. The diagram has a scale factor of 2.5 Draw the image $A'B'C'D'$.

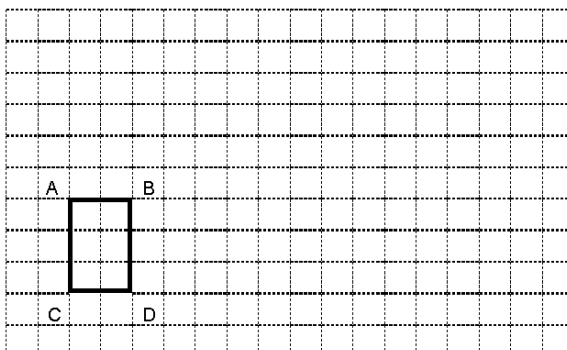

4. A hockey rink measures 52 m by 23 m. A scale diagram is drawn using a scale factor of $\frac{1}{200}$. Determine the dimensions of the rink in the scale diagram.

5. An airplane is 58 m long. A scale model of the plane is 40.6 cm long. Determine the scale factor used to create the model as a decimal and as a fraction. Hint: watch your units.

6. These quadrilaterals are similar. Determine the values of x and y° .

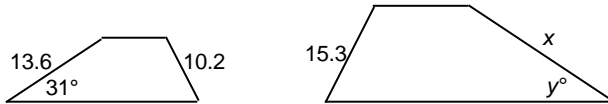

7. List what two triangles are similar and determine the length of BD.

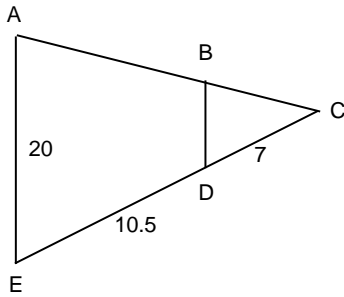

8. A tree casts a shadow of 8.3 m. At the same time a 1.2m tall person casts a shadow of 3.1 m. How tall is the tree?

9. Determine the length of RS in these similar triangles.

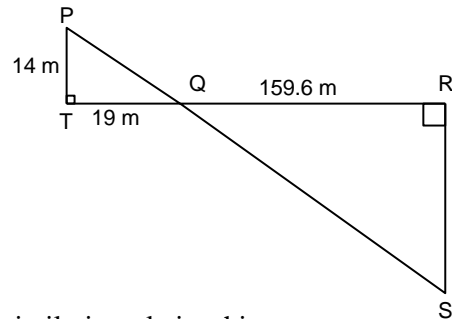

10. Circle which triangle is similar to $\triangle ABC$ and write out the similarity relationship.

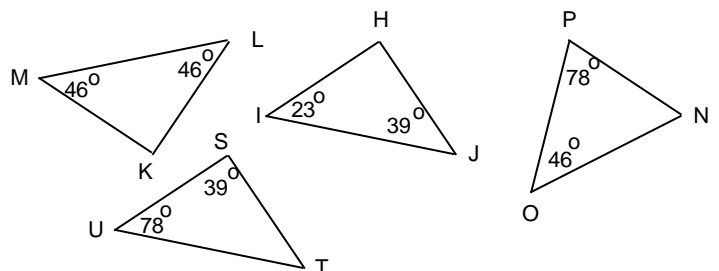
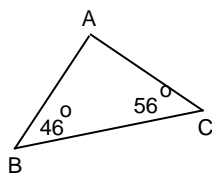

11. Which shapes have exactly one line of symmetry?

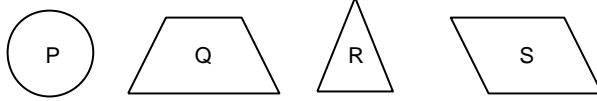

12. What's the angle of rotation symmetry for a shape that has rotational symmetry of order 6?

13. The angle of rotation symmetry for a shape is 120° . What is the order of rotational symmetry?

14. What is the order of rotational symmetry and angle of rotation symmetry for this design?

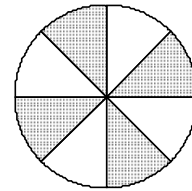

15. Draw the rotation image after rotating the shape 90° clockwise about P.

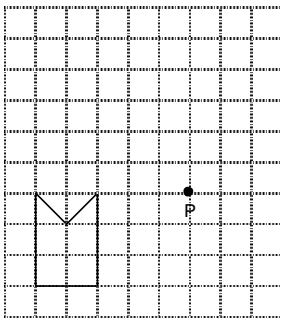

16. Circle which figure below shows objects related by both rotational symmetry and line symmetry?

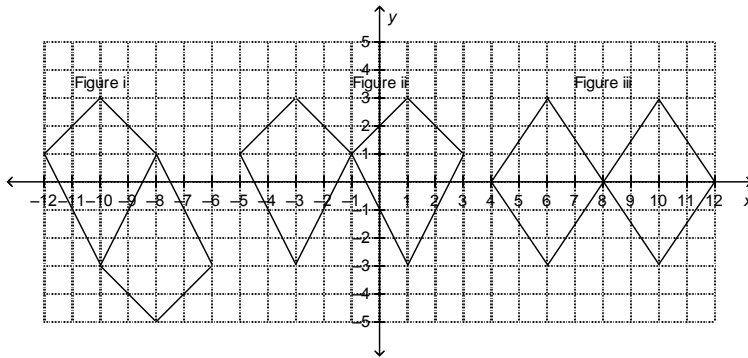

17. What type of symmetry exists in the tessellation below?

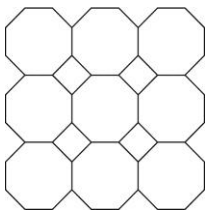

18. Which triangles are related to the shaded triangle by rotational symmetry about the origin?

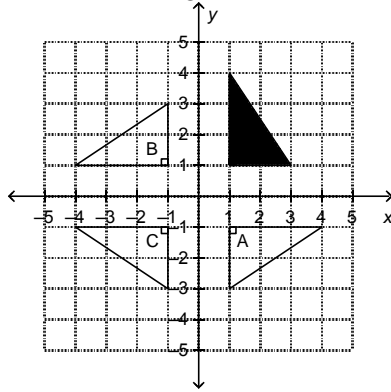

19. Draw the image of quadrilateral A after a reflection in the x -axis

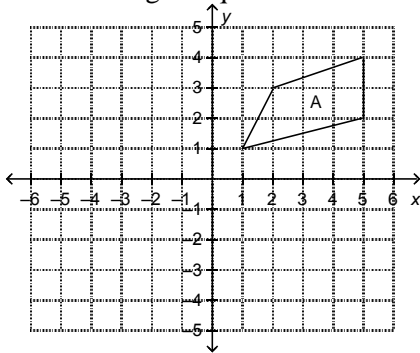

20. List the coordinates of the vertices of the image in question #20.

21. Use the grid provided to answer the following questions.

- Draw the original and the image of quadrilateral WXYZ after a translation of $2R$.
- Write the coordinates of the image formed by quadrilateral WXYZ
- Describe any symmetry in the resulting diagram.

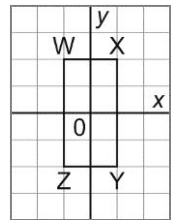

Chapter 8: Circle Geometry

1. Determine the missing value(s).

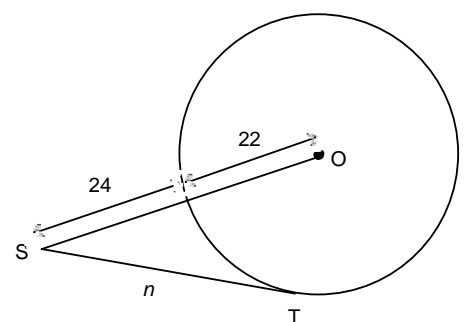
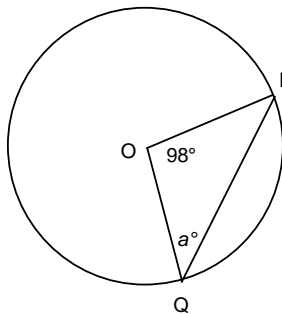
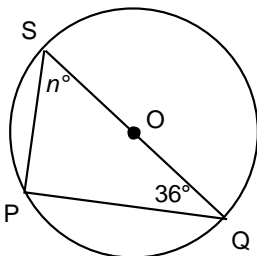
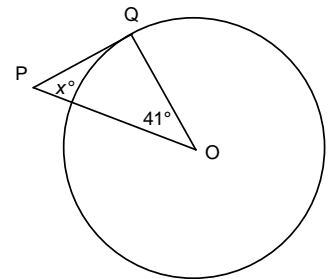
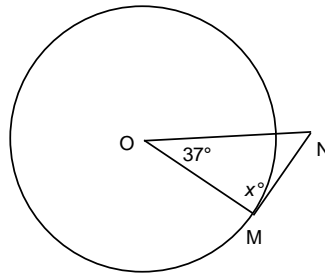
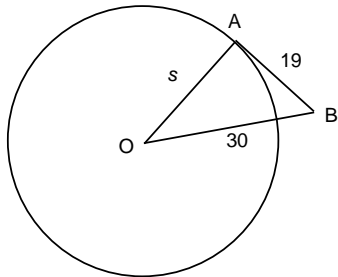

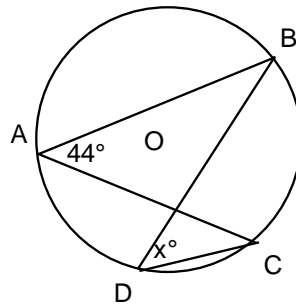
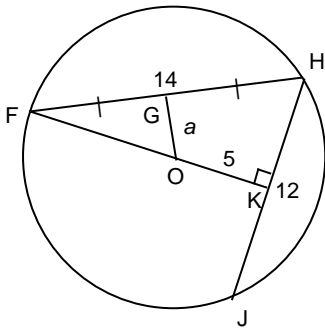
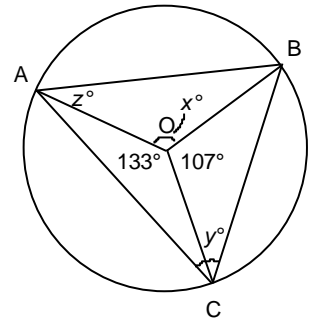
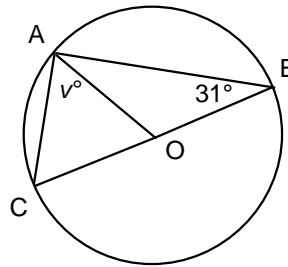
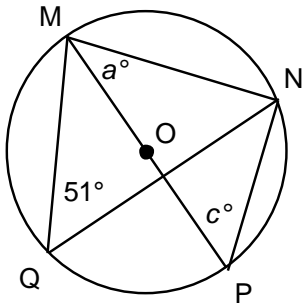
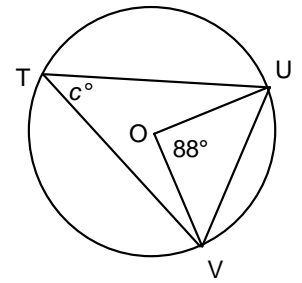
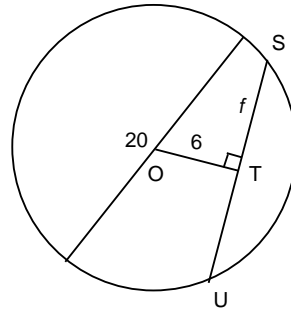
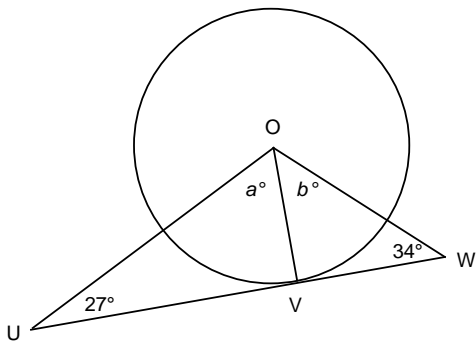

6. A pedestrian underpass is constructed using a cylindrical pipe of radius 2.6 m. The bottom of the pipe will be filled and paved. The headroom at the centre of the path is 3.9 m. How wide is the path to the nearest tenth of a meter?

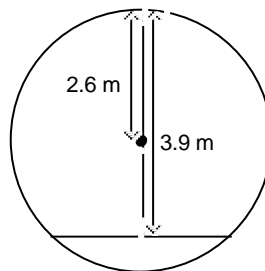

Chapter 9: Probability and Statistics

1. The last three days Alexa had a test and ate an energy bar on her way to school that morning, she did well on the test. Today she had a test, so she ate an energy bar on her way to school. Was her decision based on;
A) Theoretical Probability B) Subjective Judgment C) Experimental Probability
2. Jon's coworkers pool their money so they can buy more lottery tickets and increase their chance of winning. Was their decision based on
A) Theoretical Probability B) Subjective Judgment C) Experimental Probability
3. Haley will not go on a cruise because the boat may sink even though cruise ships are very rarely involved in accidents. Was her decision based on
A) Theoretical Probability B) Subjective Judgment C) Experimental Probability
4. A cosmetics company wants to determine which eye shadow colours are preferred by the readers of a certain fashion magazine. What is the population they are interested in surveying?
5. Drew wanted to know the proportion of grade 9 students in his school who travel to school using public transportation. Which population is he interested in surveying?
6. Determine the problem with each data collection. Choose from
A) bias/language, C) timing, D) privacy, E) cultural sensitivity, F) ethics, G) cost, and H) time.
 - a) To determine cleanliness, the school nurse asks random students from all grades how often they wash behind their ears.
 - b) Name a problem related to this data collection. Brandon wanted to collect information on students' television viewing habits. He decided to mail a questionnaire, along with a self-addressed stamped envelope, to 300 students in his school.
 - c) Name a problem related to this data collection. Bridget asked her classmates the following question: "Do you agree we spend too much time on homework?"
 - d) Anita surveyed her classmates to see if they were interested in a Christmas gift exchange.
 - e) Ed wants to find out about people's opinion on the price of gasoline. He asks "Do you think the price of gasoline is too high?"
 - f) Sally does a required project in math class and she decides to do a survey to determine how many of them own dogs. Later she opens a dog walking business because she found out that a lot of her classmates families own dogs.
 - g) The principal of Corner Brook High wants to find out the favorite music of the entire student body. He asks every student "What is your favorite type of music?"

7. Based on her previous math test scores, Maria says she is certain to get 90% on her next math test. Give an assumption she could be making.

8. Should an operator of an outdoor climbing school use a census or a sample when inspecting the climbing equipment? Why?

9. A food company wants to know what people aged 15 to 25 eat for breakfast. They interview a random sample of high school, college, and university students. What is a potential problem with this sampling method?

10. An airline manager wants to assess customer satisfaction at check-in. She decides to survey every 30th person who checks in for one week. Will the selected sample represent the population? Why?

11. Morag watched her teenage daughter play soccer at the same time every Saturday morning. She noticed that 6 out of every 10 spectators were women. She later told her husband that more women than men watch teenage soccer games. State an assumption Morag made.